

DRAWING MADE IN AMERICAN PROJECTION

LOC **G** PRINT DIST **14 D**

© 1956 BY AMP INCORPORATED. ALL RIGHTS RESERVED. AMP PRODUCTS COVERED BY PATENTS AND/OR PATENTS PENDING.

REVISIONS			
LTR	DESCRIPTION	DATE	APPROVED
C	REDRAWN & ADDED TAPE NO.	June 4-8-69	RHW
D	REVISED	P-6075 <sup>MM</sup> 2-4-70	JML

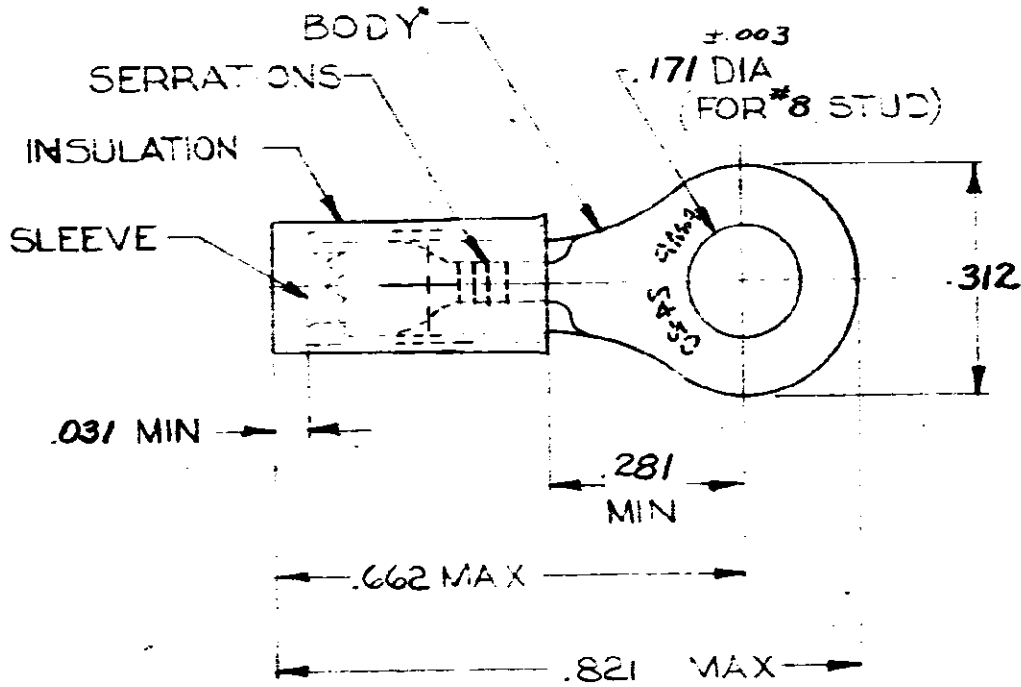

FOR .040 TO .100 WIRE INSULATION D.A.  
TONGUE MATERIAL THK. = .023<sup>±.002</sup>

1	323989 ON TAPE	1-323989-0	BODY & SLEEVE: COPPER (QQ-C-576)
1	WIRE TERMINAL	323989	INSULATION: NATURAL NYLON (MIL-M-20693) TYPE I
QTY	DESCRIPTION	PART NO.	MATERIAL & FINISH
UNLESS OTHERWISE SPECIFIED DIMENSIONS ARE IN INCHES. TOLERANCES ON: DECIMALS: .008 ANGLES: 30°		CONTRACT NO. DR. <i>PM 6/4/69</i> CHK. <i>RHW 6/8/69</i> APPD. <i>H. Young 7-15-69</i> RE. <i>PM Evening 7-15-69</i>	AMP INCORPORATED HARRISBURG, PENNSYLVANIA
MATERIAL		NAME:	WIRE TERMINAL R.I.D. & RING TONGUE WIRE SIZE: 24-20
SEE TABLE		DSGN APPD.	SIZE: <b>A</b> CODE IDENT NO.: <b>00779</b> NUMBER: <b>323989</b>
OTHER APPD.		SCALE: <b>NTS</b>	SHEET: <b>1 OF 1</b>